

## 三通 Twin socket

一条管道扩张为2条支管、最大可扩展为3条支管。

从一个流体供应源变为同时使用2-3个风动工具、在管道中途使其分流,大大提高了方便度!

- 工厂内的管道 · 压缩机等的底端 · 各种机器及机器管道等

Expand one piping to two. Possible up to three branches.  
When using 2-3 air tools at the same time from one fluid source of supply and dividing fluid circuit on the piping way., it is very convenient.

- For piping in plant
- For bottom end of compressor etc.
- For various equipments and piping of equipment

### 规格 Spec.

适用流体: 空气和水  
常用使用压力: 0.98MPa (10kgf/cm<sup>2</sup>) 以下  
使用环境温度: -20~80℃ (-4~176°F)  
使用温度范围: 0~50℃ (32~122°F)  
包装: 5pcs/箱  
Adapted fluid : Air & Water  
Working pressure : under 0.98MPa(10kgf/cm<sup>2</sup>)  
Working atmosphere : -20~80℃(-4~176°F)  
Working temperature range of fluid : 0~50℃(32~122°F)  
Packaging : 5pcs/box



型式 Model	Weight(g) 重量(g)
TL-1NR	80

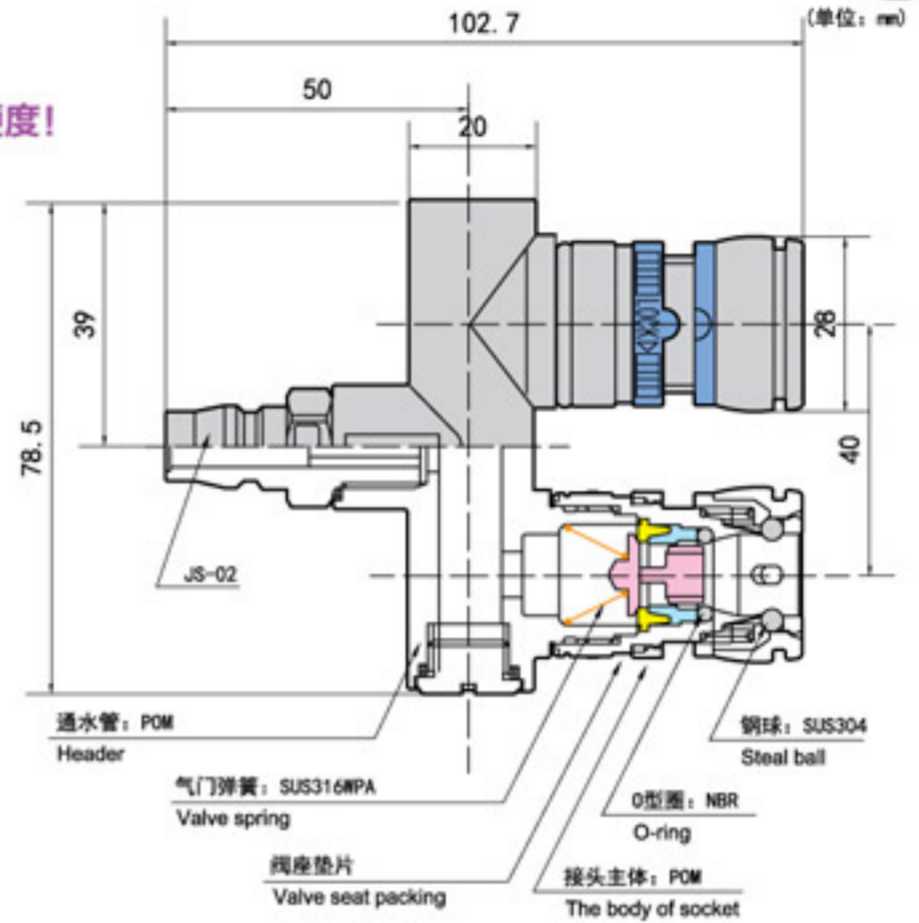

### 扩展3通的方法

3 branches expanding method

### 请准备好转接头

转接头单独出售  
please prepare socket  
sold separately

安装在普通管道时, 使用 ES系列 [TS-2NR]  
安装在水路管道时, 使用 W系列 [TS-2WR]

In the case of general piping, ES series "TS-2NR"  
In the case of water piping, W series "TS-2WR"

请将主体侧面的盖子用平头螺丝刀取下。

Please remove the side cap of the body by minus driver.

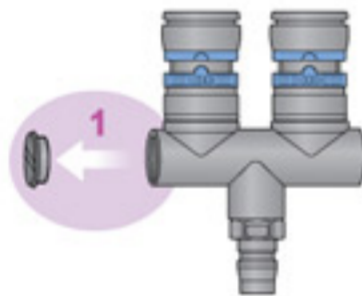

请将单独出售的转接头TS-2NR或是TS-2WR如图所示以正确的扭矩进行安装。如有必要, 可在螺丝部位进行密封加工。

Please mount TS-2NR or TS-2WR sold separately by proper torque as shown. Please do seal treatment to thread part as necessary.

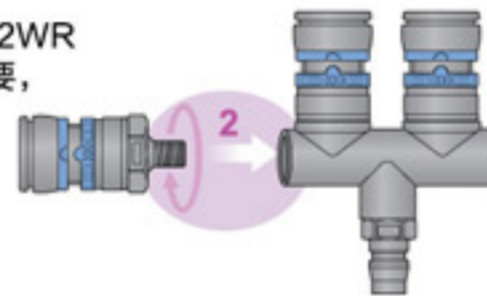

取下的盖子请务必保管好, 不要丢失。\* 盖子不单独出售, 请注意保管好。  
Please keep removed parts because of no separated selling.

### 注意!

在作业前, 请务必将本产品从管道回路上取下来, 确认其处于无压力状态。其密封性为保证对象外。

Attention! Please confirm the state with no pressure and start to remove this product from piping circuit. As for sealability, it is out of guarantee.

## 弯头型插头 Elbow plug

整洁方便! 在狭窄的地方也能很容易装卸  
更适用于自动机械设备内的管道整備。

- 各种空气管道 · 各种水路管道

Clean piping! Easy to remove and install in narrow space.

The most suitable piping preparation in the automatic machinery.

- Various air piping
- Various water piping

### 规格 Spec.

适用流体: 空气和水  
常用使用压力: 0.98MPa (10kgf/cm<sup>2</sup>) 以下  
使用环境温度: -20~80℃ (-4~176°F)  
使用温度范围: 0~50℃ (32~122°F)  
包装: 10pcs/盒  
Adapted fluid : Air & Water  
Working pressure : under 0.98MPa(10kgf/cm<sup>2</sup>)  
Working atmosphere : -20~80℃(-4~176°F)  
Working temperature range of fluid : 0~50℃(32~122°F)  
Packaging : 10pcs/box

### 竹节型

Barb type



JTL-02

JTL-03

JTL-04

Mounting hose size of the other side (inside diameter: φ mm)

型式 Model	连接另一侧 管内径 (直径 φ mm)	Weight(g) 重量(g)	(单位:mm)(Unit:mm)			
			B	L	H	D
JTL-02*	7	10	4.5	45.5	46.5	9
JTL-03	10	8	7	45.5	46.5	11.5
JTL-04	13	10	10	46.5	47.5	15

只有JTL-02的竹节内部有加固黄铜  
Only JTL-02 contains stiffening insert(brass)in the part of barb

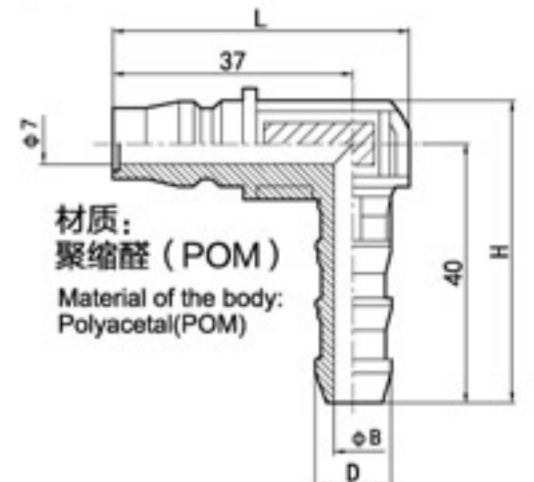

### 外螺纹型

External thread type



JSL-01

JSL-02

JSL-03

JSL-04

Mounting internal thread size of the other side

型式 Model	连接另一侧 内螺纹规格	Weight(g) 重量(g)	(单位:mm)(Unit:mm)				
			A	B	L	H	S
JSL-01	RC(PT) 1/8	6	29	5.4	45	35	R(PT)1/8
JSL-02	RC(PT) 1/4	11	30.5	7	45.5	37.5	R(PT)1/4
JSL-03	RC(PT) 3/8	8	31	10	45.5	38	R(PT)3/8
JSL-04	RC(PT) 1/2	10	33	12	46.5	40	R(PT)1/2

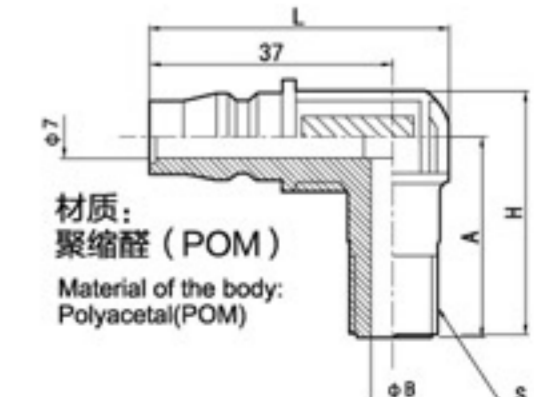

本说明书中记载的内容、构造、为改良考虑可能会在事先不通知的情况下进行更改。  
Regarding contents and specification described in this catalogue, there is some changes for improvement without any preinformation.  
本说明书中记载的数据、数值皆是选定机型时用来参考的技术支持。但是, 仅凭这些数据还不足以保证产品本身, 请顾客对此有所知晓。  
All data and figures described in this catalogue are prepared for the technical reference at decision of model. Please understand it previously.